



THE LUCKY DIME CAPER  
STARRING **Donald Duck**

**SEGA**

## Starting Up

1. Set up your Sega Master System or Master System II as described in its instruction manual. Plug in Control Pad 1.
2. Make sure the power switch is OFF. Then insert the Sega cartridge into the Power Base.
3. Turn the power switch ON. In a few moments, the Title screen appears.
4. If the Title screen doesn't appear, turn the power switch OFF. Make sure your system is set up correctly and the cartridge is properly inserted. Then turn the power switch ON again.

**Important:** Always make sure that the power switch is turned OFF when inserting or removing your Cartridge.

**Note:** This game is for one player only.

- ① Sega Cartridge
- ② Control Pad 1

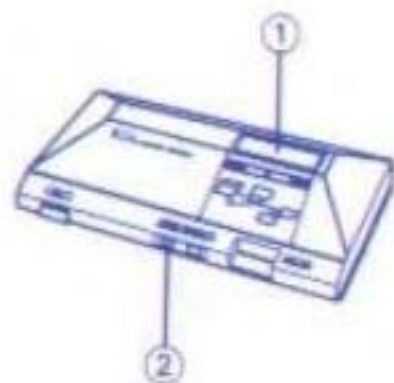

## The Search is On!

Get ready for the scariest adventure ever! Oh, but first, find out how it all began in Uncle Scrooge's grand library...

"Huey, Dewey, Louie. I have a special present for each of you. It's a Lucky Dime! Did I ever tell you that I started with only a dime, my Lucky Dime? Look how wealthy I am now!" boasts Uncle Scrooge as he hands Huey, Dewey and Louie their presents.

"Only ten cents! Nobody can get rich from a dime!" sneers Donald, as he looks over.

The billionaire turns to Donald and replies, "Well, you see, the kind of luck your dime brings you will depend on how hard you work! Understand?"

Meanwhile, a dark shadow appears in the corner of the library's window...

A few hours pass. It's time for Donald and his nephews to say goodbye to Uncle Scrooge.



Then suddenly, three ravens descend, grab Huey, Dewey and Louie, along with their Lucky Dimes, and disappear into thin air.

While Donald and Uncle Scrooge freeze in their shoes, overwhelmed by what has taken place in front of their eyes, a dark figure descends and snatches the Lucky Dime from Uncle Scrooge! It's Magica De Spell, the evil sorceress!

"Hee, hee, hee!" shrieks Magica. "Scrooge's Lucky Dimes are mine, at last! I'll use them to become filthy rich! Richer than you, Scrooge!" Then she vanishes.

What's going to happen now? Somebody has to save Huey, Dewey and Louie and restore the four Lucky Dimes! Who else is there, but Donald?! Uncle Scrooge is worried to death — about the boys and his dimes — he's even promising Donald a reward for their safe return.



Now, this is where you come in. Join Donald and search for the captured nephews and the Lucky Dimes. Pick up useful gadgets and items along the way as you tackle oncoming baddies in six treacherous lands. Then enter Magica's haunted castle, where you'll come face to face with the evil sorceress herself! She has the last dime — Uncle Scrooge's old Number One. Only Donald and you can win it back! Good luck!

## Take Control!

To help Donald get back the Lucky Dimes and rescue his three nephews, learn how to use the Control Pad before you start playing.

### ① Directional Button (D-Button)

- Press up or down to move the arrow from one selection to another on the Stage Select screen.
- Press left or right to move Donald.
- Press up to get Donald through a door.
- Press down to make Donald "duck."

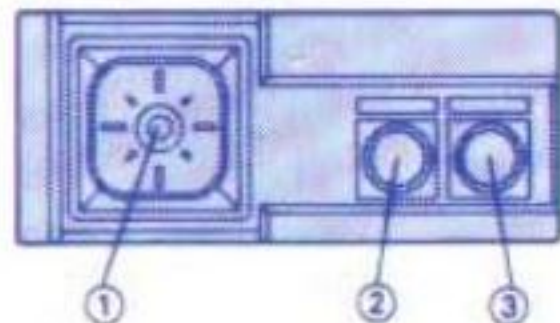

### ② Button 1

- At the Story screens, press to skip to the Stage Select screen.
- At the Title screen, press to see the Stage Select screen.
- Press to continue from the Stage Select screen.
- Press to make Donald swing a Hammer or throw a Frisbee (if he has either one). If you press Button 1 while holding the D-Button up, Donald will throw the Frisbee up.

### ③ Button 2

- At the Story screens, press to skip to the Stage Select screen.
- At the Title screen, press to see the Stage Select screen.
- Press to continue from the Stage Select screen.
- Press to make Donald jump. (Donald can attack baddies by jumping on them, too.)
- Press to make Donald let go of a rope.
- Press repeatedly to keep Donald afloat.

### Pause Button on the Power Base

- Press to pause the game during play, and then press again to continue.

## Getting Started

Read the story screens to find out how Magica De Spell stole the Lucky Dimes and captured Huey, Dewey and Louie. (Or press Button 1 or 2 to skip the screens.) At the Title screen, press Button 1 or 2 again to see the Stage Select screen.

The Stage Select screen is a map that shows Donald and you where the captured nephews and the Lucky Dimes are. (The map for the stolen Lucky Dimes won't appear until Donald rescues all three of his nephews.) Press the D-Button up or down to move the arrow to where you want to go, then press Button 1 or 2.



① Before you begin each stage, the Status screen appears. This screen shows you the following information:

- ① Stage number
- ② The number of players left
- ③ Your score

② When you clear a Stage, the Stage Clear screen appears. The screen shows you the following information:

- ① Stage number
- ② Time Bonus (if you earned any)
- ③ Your score



## Donald! Hurry!

Donald must rescue his nephews and restore the four Lucky Dimes. But there isn't a lot of time. Keep your eye on the Time Bar at the bottom of the screen. When it's blue, Donald's doing OK. But when it turns yellow, Donald must hurry because soon it will turn red — and that means danger!

- ① Time Bar

## End of Game and Continue Game

If Donald is hurt twice, runs out of time or falls to the bottom of the screen, you lose one player. When you lose all three players, the "Continue?" screen appears. If you wish to continue, press Button 1 or 2. You can play the same stage or a different one. To end the game, press the D-Button to move the arrow to No and press Button 1 or 2. The Game Over screen appears.



## Donald's Items

Items appear when Donald destroys certain baddies. He can get items by running over them or jumping on them.

- 1 Treasure Boxes: These also hold items. Break them open!
- 2 Hammer: Donald starts his quest with this device.
- 3 Frisbee: Donald can throw it and attack baddies from a distance.
- 4 1Up: This gives you an extra player.
- 5 Keys: These open locked doors.
- 6 Stars: Grab these to make Donald swing his Hammer or throw his Frisbee faster. Picking up five of these makes him temporarily invincible. (The diamond shapes that appear on the top left corner of the screen show you how many Stars you have.)



- 7 Small Gems (Yellow): These add 500 points to your score.
- 8 Large Gems (Blue): These add 1,000 points to your score.

## Donald's Dangerous Adventures

To save his nephews and restore the Lucky Dimes, Donald journeys through six thrilling stages. In the final stage, Donald confronts wicked Magica De Spell in her creepy castle!

### 1 The Northern Woods

Venture into the wilderness where mushrooms hop and spiders crawl. Keep in mind that busy beavers are mean and buzzing bees sting. The branches are slippery, so watch your step!



## 7) The Great American Forest

Carefully leap across gushing waters — one false step and you're food for the snapping wild fish! Hop on green turtles and jump on snakes! Get ready for a wet and wild trek!

## 3) The Andes Mountains

Club-throwing shamans and enchanted pots come your way — these towering mountains are threatening! Racing down the steep slopes will leave you breathless. The air's thin but you've gotta win!

## 4) The Tropical Isles

Brave crazed tribesmen and statues that spew forth red-hot flames. In the dark, dreary cave, dodge flying balls of fire and flapping bats. Be extra careful when crossing pools of hot, bubbly lava — if you trip, you're toast!

3



4



## 5) The Pyramids

More shadowy bats and deadly scorpions greet you in the dry desert. Keep jumping to escape the slippery sand traps. In the pyramid, dead mummies come alive and poisonous snakes lurk! This ancient maze is full of surprises!

## 6) The South Pole

Brr! You're caught in a heavy snowstorm! Slide on chunks of ice and tackle vicious ice monsters. The snowmen in the freezing caves aren't as friendly as they look! If you survive this chilling stage, you're bound for Magica's castle!

## 7) Magica's Castle

Skeletons in silk hats and tricky poltergeists. Spooky mirrors and haunted portraits. They're all out to get you! But you must go on! Magica's chamber is just a step away!

2



5





## Dime-Hunting Hints

- Learn how all the different baddies move. It'll be easier for you to defeat them.
- Donald can reach high places by bouncing off baddies.
- Donald can't use the Hammer or the Frisbee while swimming.
- Remember: when you lose one player, you also lose any Keys or Stars you have picked up.
- Don't waste any time! If you finish a Stage fast enough, you earn a Time Bonus.

## Handling This Cartridge

This Cartridge is intended exclusively for the Sega System.

### For Proper Usage

- (1) Do not immerse in water!
  - (2) Do not bend!
  - (3) Do not subject to any violent impact!
  - (4) Do not expose to direct sunlight!
  - (5) Do not damage or disfigure!
  - (6) Do not place near any high temperature source!
  - (7) Do not expose to thinner, benzene, etc.!
- When wet, dry completely before using.
  - When it becomes dirty, carefully wipe it with a soft cloth dipped in soapy water.
  - After use, put it in its case.
- \* Be sure to take an occasional recess during extended play.

**WARNING:** For owners of projection televisions. Still pictures or images may cause permanent picture tube damage or mark phosphor of the CRT. Avoid repeated or extended use of video games on large screen projection televisions.





## SCOREBOOK

Name			
Date			
Score			

Name			
Date			
Score			

Name			
Date			
Score			

Name			
Date			
Score			



### SCOREBOOK

Name			
Date			
Score			

Name			
Date			
Score			

Name			
Date			
Score			

Name			
Date			
Score			

### SCOREBOOK

Name			
Date			
Score			

Name			
Date			
Score			

Name			
Date			
Score			

Name			
Date			
Score			

**SEGA**