



(12) **EUROPEAN PATENT APPLICATION**

(88) Date of publication A3:  
**21.09.2005 Bulletin 2005/38**

(51) Int Cl.7: **G06T 1/00**, A63F 13/10,  
A63F 13/06

(43) Date of publication A2:  
**19.01.2005 Bulletin 2005/03**

(21) Application number: **04077411.9**

(22) Date of filing: **05.06.1997**

(84) Designated Contracting States:  
**DE ES FR GB IT**

(72) Inventors:  

- **Oba, Norikatsu c/o Sega Enterprises, Ltd. Tokyo 144 (JP)**
- **Ono, Kenichi c/o Sega Enterprises, Ltd. Tokyo 144 (JP)**

(30) Priority: **05.06.1996 JP 14333796**

(62) Document number(s) of the earlier application(s) in accordance with Art. 76 EPC:  
**97925285.5 / 0 844 587**

(74) Representative: **Style, Kelda Camilla Karen Page White & Farrer, 54 Doughty Street London WC1N 2LS (GB)**

(71) Applicant: **SEGA ENTERPRISES, LTD. Tokyo 144 (JP)**

(54) **Graphics processing device, graphics processing method, game machine, and storage medium**

(57) A graphics processing device for generating representations of segments defined three-dimensionally within virtual space displayed as viewed from the viewing point, comprising cursor generation means for generating a cursor, cursor moving means for moving

the cursor through operation by the player, data generating means for acquiring data concerning segments located peripherally around the cursor and generating display data and data display means for producing data displays on the basis of the display data.

*F I G. 12*

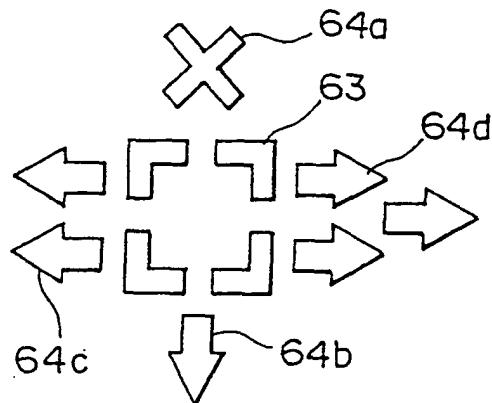



European Patent Office

EUROPEAN SEARCH REPORT

Application Number  
EP 04 07 7411

DOCUMENTS CONSIDERED TO BE RELEVANT			
Category	Citation of document with indication, where appropriate, of relevant passages	Relevant to claim	CLASSIFICATION OF THE APPLICATION (Int.Cl.6)
X	US 5 415 549 A (LOGG G EDWARD) 16 May 1995 (1995-05-16) * figures 6,8a-8c,18a-c * * column 11, lines 39-47 * * column 12, lines 16-20 * * column 15, lines 53-58 * * column 13, line 17 - line 68 * -----	1	G06T1/00 A63F13/10 A63F13/06
X	UNKNOWN: "TEMPEST - Operation, Maintenance, Service MANUAL" [Online] 1980, ATARI , XP002325423 Retrieved from the Internet: URL:http://www.arcadedocs.com/vidmanuals/T/Tempest.pdf> [retrieved on 2005-04-20] * page 14 - page 16 * * page 15, column 2 * -----	1	TECHNICAL FIELDS SEARCHED (Int.Cl.6)  A63F G06T
X	ATARI: "TEMPEST" KLOV COIN-OP MUSEUM, [Online] 1980, XP002325540 Retrieved from the Internet: URL:http://www.klov.com/game_detail.php?&ame_id=10065> [retrieved on 2005-04-20] * figures 1-3 * -----	1	
X	US 5 463 722 A (VENOLIA ET AL) 31 October 1995 (1995-10-31) * abstract * * columns 17-19 * * figures 5,6,9,10 * ----- -/--	1	
-The present search report has been drawn up for all claims			
Place of search Munich		Date of completion of the search 21 April 2005	Examiner Ruf, A
<p>CATEGORY OF CITED DOCUMENTS</p> <p>X : particularly relevant if taken alone Y : particularly relevant if combined with another document of the same category A : technological background O : non-written disclosure P : intermediate document</p> <p>T : theory or principle underlying the invention E : earlier patent document, but published on, or after the filing date D : document cited in the application L : document cited for other reasons ..... &amp; : member of the same patent family, corresponding document</p>			

7  
EPO FORM 1503 03.82 (P04/C01)



European Patent  
Office

EUROPEAN SEARCH REPORT

Application Number  
EP 04 07 7411

DOCUMENTS CONSIDERED TO BE RELEVANT			
Category	Citation of document with indication, where appropriate, of relevant passages	Relevant to claim	CLASSIFICATION OF THE APPLICATION (Int.Cl.6)
X	CHRIS SAWYER: "TRANSPORT TYCOON DELUXE & World Editor" 1995, MICROPROSE LTD, BRISTOL, XP002325424 * pages 1-9 * * pages 25-43 * * pages 45-57 * * pages 70-87 * * figure 1-18 * Custom screenshots of the actual game.	1-6,12	
A	----- PATENT ABSTRACTS OF JAPAN vol. 1995, no. 10, 30 November 1995 (1995-11-30) & JP 07 178246 A (SEGA ENTERP LTD), 18 July 1995 (1995-07-18) * abstract * -----	1-6,12	
			TECHNICAL FIELDS SEARCHED (Int.Cl.6)
<del>The present search report has been drawn up for all claims</del>			
Place of search Munich		Date of completion of the search 21 April 2005	Examiner Ruf, A
<p>CATEGORY OF CITED DOCUMENTS</p> <p>X : particularly relevant if taken alone Y : particularly relevant if combined with another document of the same category A : technological background O : non-written disclosure P : intermediate document</p> <p>T : theory or principle underlying the invention E : earlier patent document, but published on, or after the filing date D : document cited in the application L : document cited for other reasons ..... &amp; : member of the same patent family, corresponding document</p>			

7  
EPO FORM 1503 03.82 (P04C01)



**CLAIMS INCURRING FEES**

The present European patent application comprised at the time of filing more than ten claims.

- Only part of the claims have been paid within the prescribed time limit. The present European search report has been drawn up for the first ten claims and for those claims for which claims fees have been paid, namely claim(s):
  
- No claims fees have been paid within the prescribed time limit. The present European search report has been drawn up for the first ten claims.

**LACK OF UNITY OF INVENTION**

The Search Division considers that the present European patent application does not comply with the requirements of unity of invention and relates to several inventions or groups of inventions, namely:

see sheet B

- All further search fees have been paid within the fixed time limit. The present European search report has been drawn up for all claims.
  
- As all searchable claims could be searched without effort justifying an additional fee, the Search Division did not invite payment of any additional fee.
  
- Only part of the further search fees have been paid within the fixed time limit. The present European search report has been drawn up for those parts of the European patent application which relate to the inventions in respect of which search fees have been paid, namely claims:
  
- None of the further search fees have been paid within the fixed time limit. The present European search report has been drawn up for those parts of the European patent application which relate to the invention first mentioned in the claims, namely claims:

1-6, 12



The Search Division considers that the present European patent application does not comply with the requirements of unity of invention and relates to several inventions or groups of inventions, namely:

1. claims: 1-6,12

Generating and displaying a cursor based on segments in vicinity of the current position

---

2. claims: 7-11,13

Modifying the attributes of a moved segment (player character) based on a state before/after movement;

---

ANNEX TO THE EUROPEAN SEARCH REPORT  
ON EUROPEAN PATENT APPLICATION NO.

EP 04 07 7411

This annex lists the patent family members relating to the patent documents cited in the above-mentioned European search report. The members are as contained in the European Patent Office EDP file on the European Patent Office is in no way liable for these particulars which are merely given for the purpose of information.

21-04-2005

Patent document cited in search report	Publication date	Patent family member(s)	Publication date	
US 5415549	A	16-05-1995	EP 0576635 A1	05-01-1994
			JP 6507736 T	01-09-1994
			WO 9216924 A2	01-10-1992
			US 5616031 A	01-04-1997
-----				
US 5463722	A	31-10-1995	NONE	
-----				
JP 07178246	A	18-07-1995	JP 3421746 B2	30-06-2003
-----				