

SEGA[®]

EXERION[™]

HOW TO PLAY

For 1 or 2 players

Shoot down the enemy by effectively utilizing the "Dual Beam" with its high target hit ratio and the swiftly attacking type "Single Beam".

The point of the game lies in speedy movements and how to effectively utilize the the 2 kinds of arms — the "Dual Beam" and the "Single Beam". This is an up-to-date space war game that enables you to enjoy the distinct images on the screen as well.

EXERION™

BEFORE YOU START....

1. This Game Cartridge is intended for SEGA Personal Computer SC-3000 or Computer Video Game SG-1000.
2. Turn the power switch on after inserting the Cartridge in the ROM Cartridge Inlet of the Body. The Body and /or the Cartridge may be damaged if you insert the Cartridge in the Body without turning the power off.
3. Use the Joystick when playing the game on the SG-1000. When playing the game on the SC-3000, either the Keyboard or the Joystick (an option) is usable.
4. **JOYSTICK:** When using the JOYSTICK with SC-3000, connect it with "JOY 1." When two players play the game, connect it with "JOY 2." also.
5. **KEYBOARD:** Refer to the drawing.
6. Pull out the Cartridge after turning the power off. Keep it in its case and handle with extreme care.

When playing by using the KEYBOARD (SC-3000)

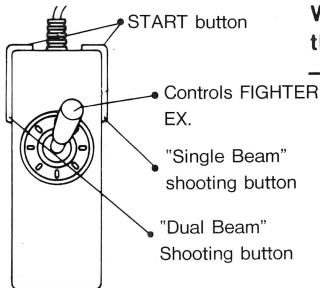
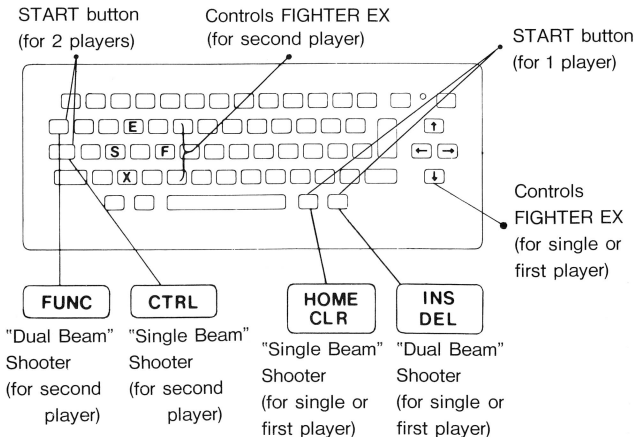

When playing by the JOYSTICK

EXERION™

How To Play

- * When playing by using the JOYSTICK
For 1 player, connect the JOYSTICK to "JOY 1" and press the START button.
For 2 players, connect the JOYSTICK to "JOY 1" and "JOY 2" and then press the START button of "JOY 2".
- * When playing by using the KEYBOARD (SC-3000) refer to the illustration.
- * Control FIGHTER EX in 8 directions by using the JOYSTICK or the control keys to shoot down the enemy.
- * FIGHTER EX is equipped with the "Single Beam" and the "Dual Beam".
The former can be shot continuously by keeping the "Single Beam" button pressed down.
- * The "Single Beam" can not be used when the "CHARGE" indication on the right hand side of the screen becomes 0. If the beam hits the enemy, however, the numerals corresponding to the number of hits will be added to the "CHARGE" figure.
The number of FIGHTER EXes allowed for 1 game is 3 and the player can earn one additional FIGHTER EX only once when the point total exceeds 10,000 (thus the maximum number of FIGHTERS Exes that can be used for 1 game is 4).

SCORE

Round	Scene	Points earned by destroying one enemy flying object.	
1	1 & 4	100	POINTS
	2 & 5	200	POINTS
	3 & 6	300	POINTS
2	7 & 10	200	POINTS
	8 & 11	300	POINTS
	9 & 12	400	POINTS
3	13 & 16	300	POINTS
	14 & 17	400	POINTS
	15 & 18	500	POINTS

Thereafter, points earned increase
in the same manner as above.

CAUTION:

This game is one of SEGA's original products. The sales of program contents by copying them without permission, whether partially or wholly, is strictly prohibited.



SEGA ENTERPRISES, LTD.

Head Office: 2-12, Haneda 1-chome, Ohta-ku,
Tokyo 144, Japan Tel: 03-742-3171

For inquiries, please contact the Personal Computer Division